



**CONFIDENCE**  
*at work*

**CENTURY**  
SEATING SYSTEM



**ENMORE**



**LEGEND**



**FEATURES:**

- Sleek robust design
- Available in white or black frame finish
- Black Mesh with standard black seat
- Synchron tilt lock mechanism
- Adjustable lumbar support
- Adjustable arm
- Polished base with 60mm castor
- 110kg weight rating

- **ENKBRA**  
Black frame
- **ENKWRA**  
White frame

ENMORE		DIMENSIONS (mm)	
SEAT		BACK	
H	W	D	H
405-500	515	460	540



**Optional:**

- Black nylon base

**FEATURES:**

- Unique slimline design
- Contoured mesh upholstery
- Moulded and contoured polypropylene frame
- Polished aluminium base
- Concealed chrome seat adjustment controls
- Gas height adjustment
- Wire control mechanism with tilt and one position locking
- Black mesh
- 110kg weight rating

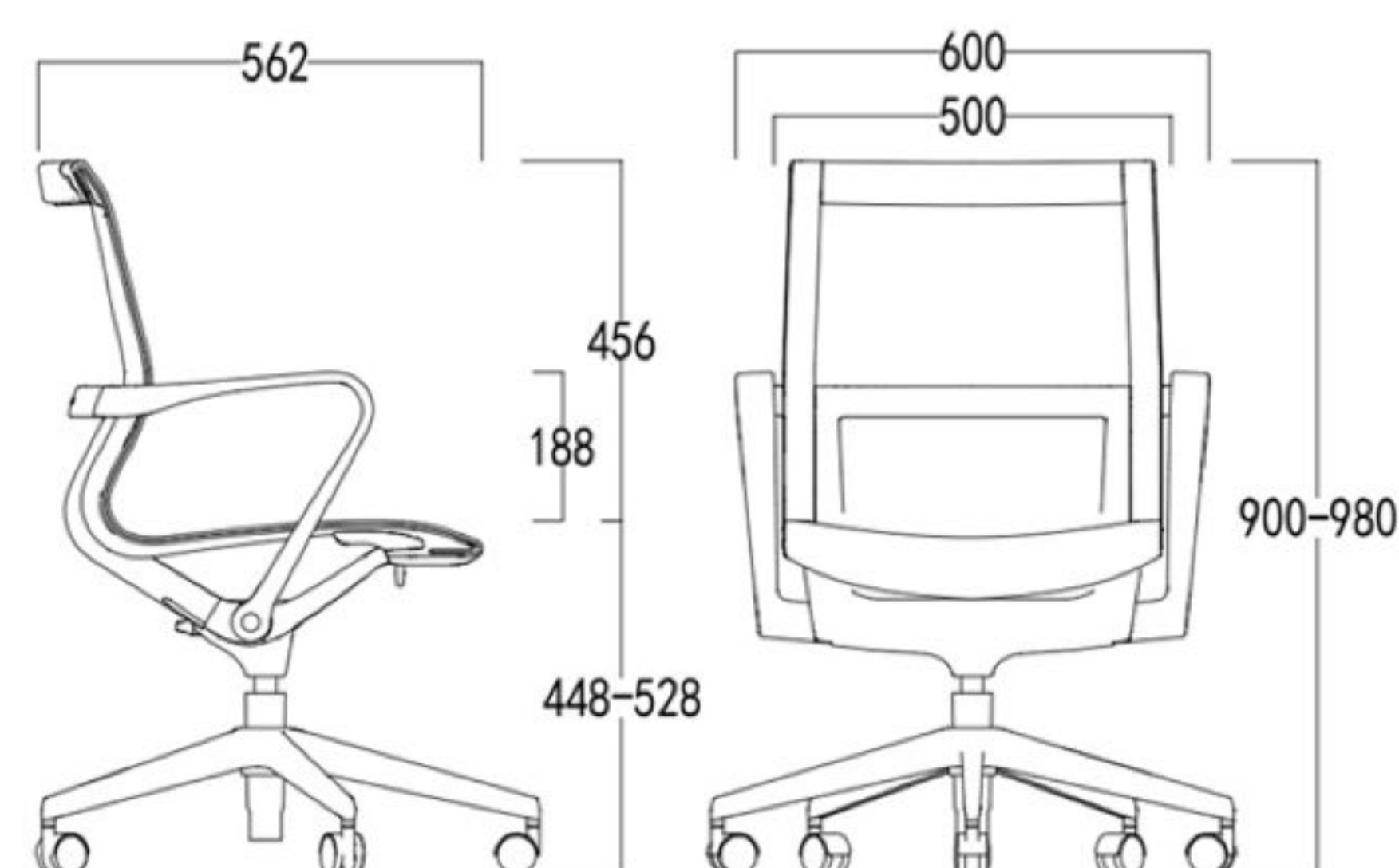

02 9708 6163



www.centuryseating.com.au

All chairs are subject to change without prior notice. We reserve the right to change design, colours, specifications and dimensions without notice. v19-20

Note: All measurements are approximate and may vary slightly from the listed dimensions.