



CONFIDENCE
at work

CENTURY
SEATING SYSTEM



M1



M2



M3

MORIKA

Features:

- Removable tablet arm
- Available with plastic seat and back, sled frame
- Stackable and the ability to link in lines with a solid device
- Standard colours are: **Blue, Red, Black, White, Green & Grey.**
- Available in bar stool height
- Compliance with the requirements for strength, durability and safety levels of EN 15373:2007.
- 110kg weight rating



M5

M4

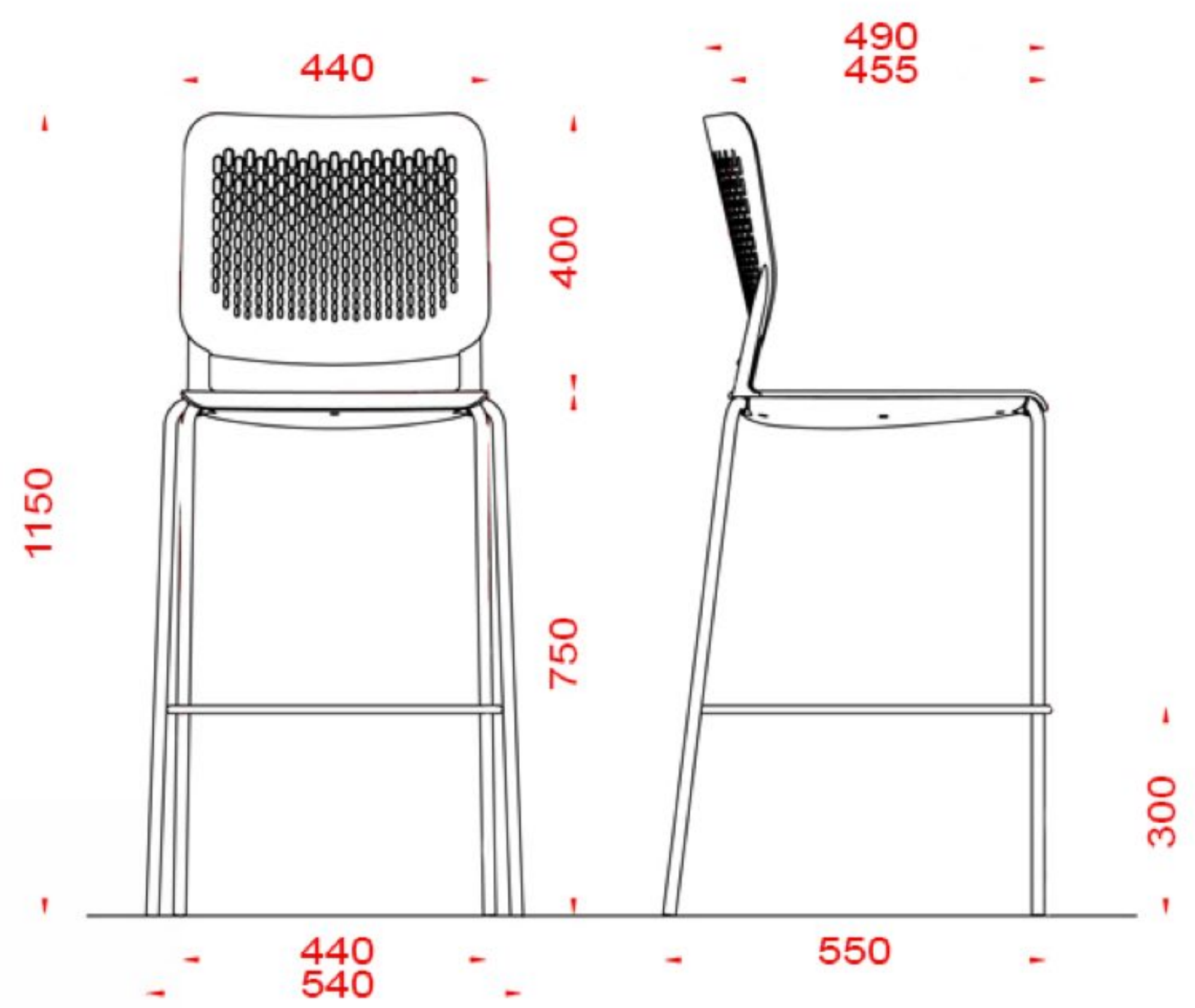
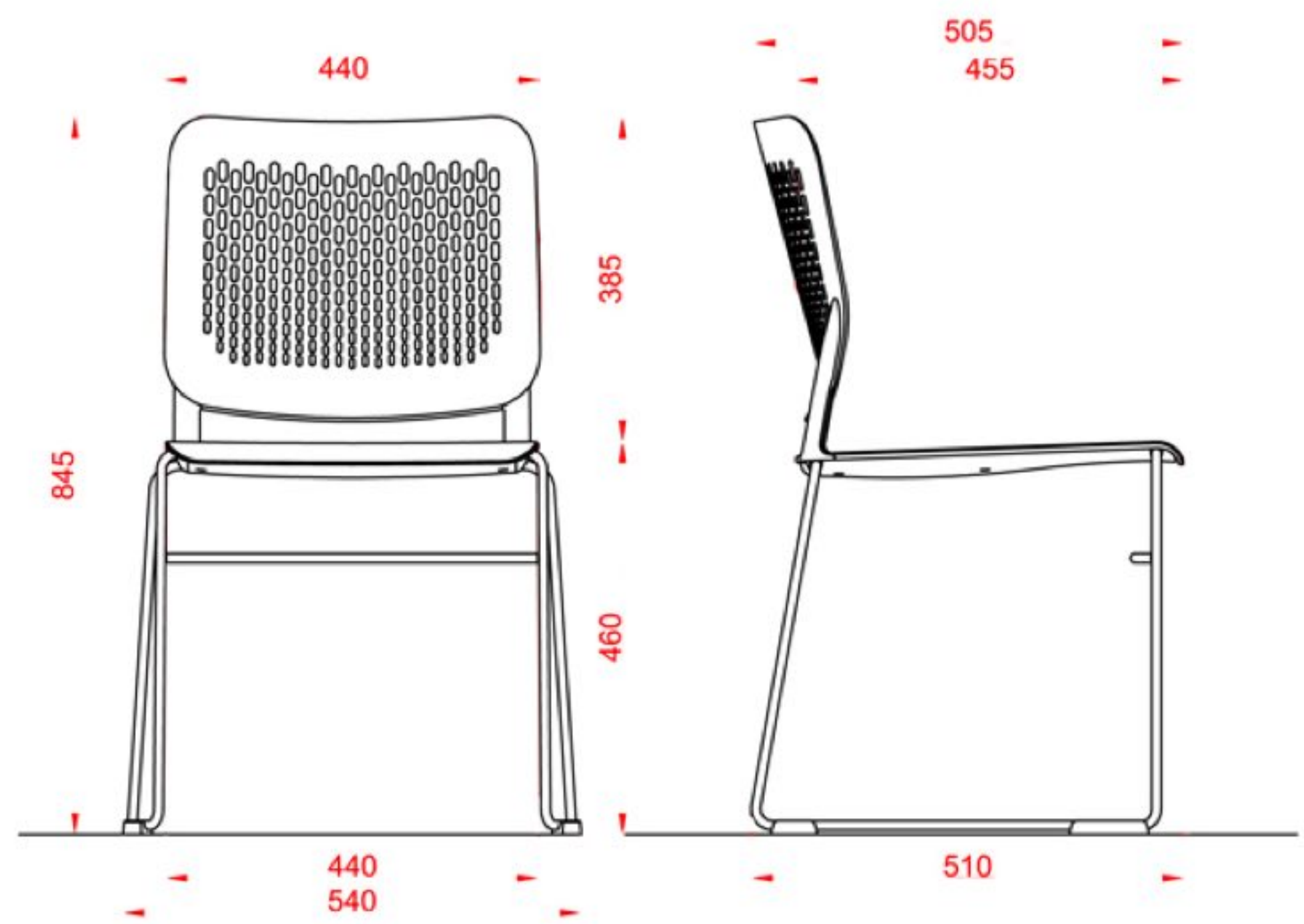

M6



SHELL COLOR:



02 9708 6163

www.centuryseating.com.au

All chairs are subject to change without prior notice. We reserve the right to change design, colours, specifications and dimensions without notice. v19-20

Note: All measurements are approximate and may vary slightly from the listed dimensions.